

PURE GOLD

WINDING TOOLS



GOLDENROD



CORPORATION

CHOOSE THE INDUSTRY LEADER!

ABOUT GOLDENROD CORPORATION

Goldenrod Corporation was founded in 1986 as an affiliate of Svecom P.E., Vincenza, Italy. Reaching beyond our initial function as a distributor to North America, Goldenrod moved into a fully equipped facility in 1993 to manufacture winding shafts and chucks for all customers in the converting, paper, film, foil, textile, tissue, nonwovens and metals industries. The company continued its expansion in 2003 by moving to a newly built 30,000 ft² manufacturing facility in Beacon Falls, Connecticut.

MOVING THE INDUSTRY FORWARD

Today, Goldenrod and Svecom combine for more than 50 years of experience. We offer the greatest variety of roll-handling tools in the world, with a product list that includes state-of-the-art differential shafts, lightweight and ultra-lightweight winding and slitting shafts, reel spool shafts, chucks, safety chucks, and a complete line of shaft handling equipment. Our product achievements and close attention to customer needs have made us an industry pioneer, giving our competitors no choice but to follow our lead.

THE MULTIPLE BLADDER ADVANTAGE

The defining feature of Goldenrod products is the multiple bladder design. This unique approach allows the number and width of gripping ledges to change to handle each specific application. Developed to solve problems caused by old-style lug and button shafts, the multiple bladder design is incorporated into Goldenrod shafts and chucks to provide years of trouble-free use and reliable operation.

Goldenrod is the industry leader in multiple bladder technology, offering over 50 multi-bladder variations.

HELPING OUR CUSTOMERS SUCCEED

Our mission is to give our customers the tools they need to improve manufacturing efficiency and safety, increase productivity and, ultimately, enhance profitability. To this end, we offer:

- "L"ong life, low maintenance and minimal downtime with our reliable and durable products
 - "E"xtensive technical assistance, provided by trained local sales and service staff
 - "A"ggressive quality assurance and professional customer service
 - "N"ew and innovative designs for high technology winding solutions
- ... and global sales and support, through our North American and worldwide network of technical personnel

GOLDENROD IS THE LEADER IN MULTIPLE BLADDER TECHNOLOGY, OFFERING OVER 50 UNIQUE MULTI-BLADDER VARIATIONS – MORE THAN ANY OTHER COMPANY!

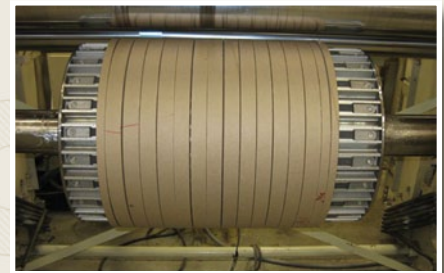

Metal strip rewind



Differential



Duplex



Splicer



Cam-Lock differential

GOLDENROD DIFFERENTIAL SHAFTS – THE DIFFERENCE IS IN THE DETAILS!

There's a reason Goldenrod is the #1 seller of differential winding shafts in the world. The company's unique, field-proven DFX shafts are the most flexible differentials in the industry, featuring superior tension range and Goldenrod's patented expanding core stops for precise and repeatable alignment. DFX shafts are available in aluminum, carbon fiber, and steel designs for virtually any application, and are available in sizes from 1" to 12" diameters and beyond.

Goldenrod also offers customers a full line of Cam-Lock differential shafts. Goldenrod's Cam-Lock differentials are designed to support the highest weight rolls of any Cam-Lock shaft in the industry. All Goldenrod Cam-Locks are custom built for your specific application and available in diameters of 3" to 12" and beyond.

BENEFITS OF GOLDENROD DIFFERENTIAL SHAFTS

1250 DFX

- Quick and easy setup – no spacers. Dramatically reduces setup time
- Differential width cores as narrow as 1" can be wound on the same shaft at the same web tension
- Available for core ID's as small as 1" in diameter
- 6" diameter and up can be made as slipover adapters
- Patented DFB model differential with surface roller bearings minimizes drag on larger diameter cores
- Available in aluminum, steel, and carbon fiber
- Patented, adjustable core stop cassette system allows for rapid changeover and saved setups
- Engineered to handle low tensions and high roll weight

1250 CL (CAM-LOCK)

- Engineered to support the highest roll weight of any Cam-Lock shaft in the industry
- Spring loaded ball bearings available to assist core positioning and winder start-up
- Requires no lubrication
- Base shaft designed to accept multiple ring diameters, simple changeover from 3" to 6" cores
- Minimizes core dusting
- All metal rings (no plastic) are chrome-plated



1250-DFX
Differential Shaft



1250-CL
Cam-Lock Style
Differential Shaft

EXPANDING SHAFTS

Each Goldenrod shaft is customized to meet your exact needs and requirements for increased productivity, and manufactured for long life and low maintenance.

MULTIPLE BLADDER

The industry's most popular performance-driven pneumatic shaft.

- Multiple external tubes filled through a common source (LDX) or the patented Fail-Safe internal check valve system (LD)
- Greater expansion for easier core loading and unloading (3/8" or more)
- Continuous rubber expanders extend the length of the shaft
- Grips cores with almost twice the force of conventional shafts
- 10 minute bladder repair
- Steel-backed expanders protect bladders – razor proof
- Always deflates completely below the shaft surface



1260-LDX

SLITTER DRIVE SHAFTS

Precision machined to exacting tolerances and finish to eliminate axial misalignment of knives. Perfect for automated systems.

- Multiple bladder style body is ground, chromed and reground to $\pm .0005$ " end to end tolerance
- Shaft turned entirely from one piece of solid steel
- Bottom knives are securely held with wide, uninterrupted rubber gripping ledges
- No tools are needed to re-position knives
- Reduced changeover time
- Fast ROI



1280-CT

LIGHTWEIGHT SHAFTS

Strong patented designs and materials meet safety requirements and reduce downtime.

- Lightest 3" and 6" aluminum shafts on the market
- Lighter and less expensive than composite lug shafts
- Various 3", 4", 5", 6" and 6.75" models available
- Bolt-on journals available
- Multiple bladder design – fast delivery, fast expansion, fast repairs

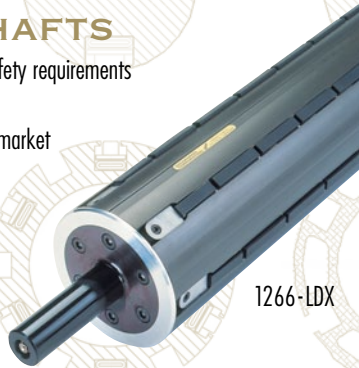

1266-LDX

SMALL DIAMETER SHAFTS

Locked core and differential shafts ideal for tape, film and ribbon rewind applications.

- Small diameter (1" to 1.5") shafts available in lengths up to 100"
- Each shaft features three rows of external gripping elements (locked core) or extremely low friction, abrasion-resistant ledges (slip differential) for excellent control of low tension web substrates.
- Each shaft turned from single piece of steel – no weak journal/body connections, so shaft can hold more weight with less deflection



1260-LDX

ROLL CENTERING SHAFTS

Ensuring a perfect unwind or rewind at high linear speeds.

- Pneumatic, pneumatic/mechanical, and mechanical
- Metal ledges expand first to hold cores above and concentric to shaft body before expansion of the rubber gripping ledges
- All bladders filled through a single valve (LDBX), and available with patented Internal Check Valve system (LDB)
- Prevents loping and allows higher winding speeds
- Improved finished roll quality (low wrinkles and defects) and longer shaft life
- Excellent for printing, laminating or coating applications
- Excellent for foils or metallized films



1260-LDB

ULTRA-LIGHTWEIGHT MULTIPLE BLADDER LEAF SHAFTS

The lightest weight 3" air shaft on the market, a perfect choice for light duty applications or drum winding.

- Weighs just 0.25 lbs. per inch of body length
- All aluminum construction with customized hardened steel ends
- Simple maintenance – multiple bladder design allows for 10 minute or less bladder changes
- Strong design – handles medium-duty single rolls and light duty multiple rolls



1260-LF

CORELESS SHAFTS

Multiple designs for winding paper, film or foil with no core.

- Saves converters thousands in core costs
- Eliminates need for core disposal
- Multiple bladder design



1260-LFT

LARGE DIAMETER / MILLED BODY SHAFTS (REEL SPOOLS)

The most common pneumatic shaft in the tissue and paperboard markets.

- Heavy duty LDB models with both Centering and Internal Check Valves
- Unique 3-port inflation/deflation system ensures perfect centering and complete deflation
- Balanced to the most critical Grade G-1.6 standards
- Available in steel, aluminum or steel-sleeved carbon fiber



1260-LDB

GOLDENROD CARBON PULTRUSION SHAFTS — THE DIFFERENCE IS IN THE DETAILS!

Goldenrod manufactures the industry's only carbon fiber multiple bladder shaft — the lightest weight, yet most rigid winding shaft on the market. Our patented carbon fiber pultrusion design means all fibers are oriented in the same direction, not wound like competitor's models. This allows for superior stiffness and winding speeds.

BENEFITS OF GOLDENROD CARBON PULTRUSION SHAFTS

Lowest Deflections. Low Inertia. Highest Critical Speeds. Lightweight and strong multiple bladder or steel-sleeved composite lug designs. It all adds up to the best performing, lightest weight shafts available today.

- Lightest composite shafts on the market
- Patented multiple bladder pultrusion design in high and super-high modulus carbon fiber
- Composite material completely surrounded and protected by metal
- Journals seat into metal for strong connection
- Extremely low inertia for the highest rotational speeds
- Best stiffness due to patented pultrusion carbon-fiber construction
- Multiple rows of gripping elements along the entire length of the shaft
- "No-Cut" carbon design for superior strength
- Faster rotation — as much as 200% faster winding than steel shafts
- Bladders can be replaced in 10 minutes or less
- Available in 3", 4", 5", 6", and 6.75" diameters

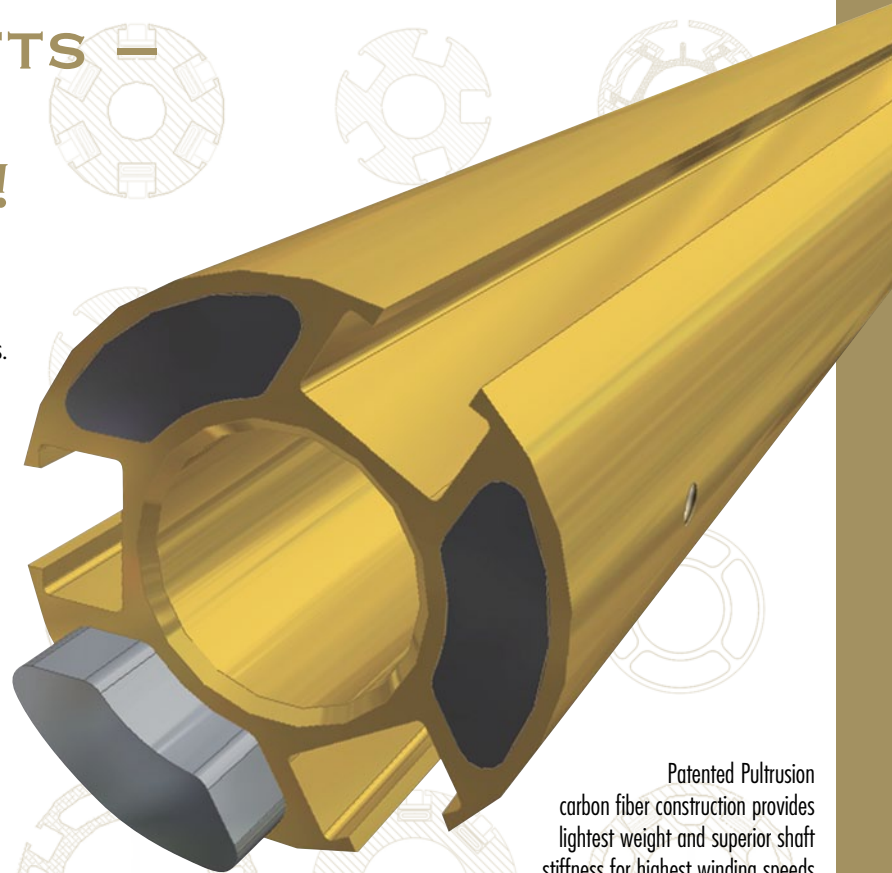

Patented Pultrusion carbon fiber construction provides lightest weight and superior shaft stiffness for highest winding speeds

EASE OF MAINTENANCE

For All Goldenrod Multiple Bladder Shafts

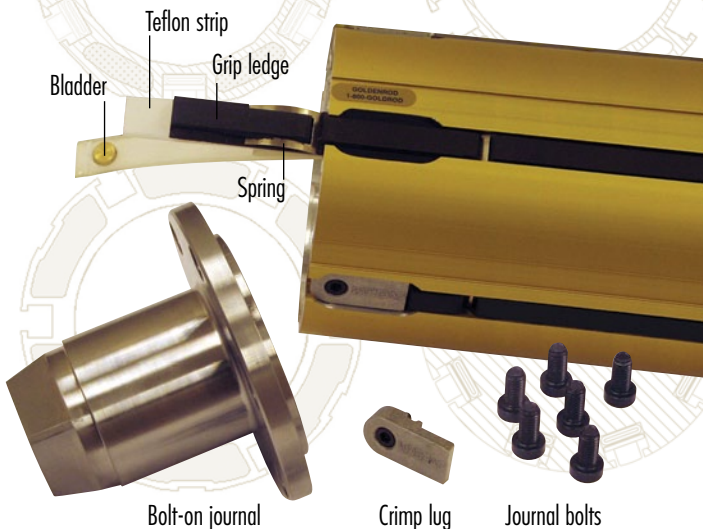

COST/BENEFIT ANALYSIS

Internal Bladder vs. Goldenrod External Bladder
Maintenance costs

Example Application

- 60" Aluminum Body Shaft / OAL 64"
- Hardened Square Safety Chuck Journals
- Unwind — Film — 1200 Pound Rolls — 1000 FPM
- Shaft is used 3 shifts per day

Internal Bladder (Lug, Button or Leaf Style)

Bladder & Fittings:	\$65.00
3 hrs Labor @ \$45/hr:	\$135.00
Total Cost per Repair:	\$200.00

Goldenrod External Bladder (Multi-ledge)

Bladder & Fittings:	\$25.00
10 Minutes Labor @ \$45/hr:	\$7.50
Total Cost per Repair:	\$32.50

SAVINGS PER REPAIR:

\$167.50

See For Yourself — Bladder Replacement In 2 Minutes
Watch The Video at www.GOLDENRODCORP.com

EXPANDING CHUCKS

Goldenrod offers a complete family of hard-working expanding chucks in a full range of sizes and styles for your shaftless applications.

PNEUMATIC/MECHANICAL CHUCKS

Concentric mechanical expansion with the ease of air inflation

- Air-driven piston forces expanders up inclined planes, providing perfect roll-centering and strong gripping
- Heavy duty steel flange or special shaft mounted design
- Optional constant air/spring retract and spring expand/air deflate safety designs
- Base chucks can accept core adapters for quick changeover
- Several 3" designs with various diameter core adapters in stock
- Patented 1420-LFH Hybrid design for the highest torque requirements and steel cores

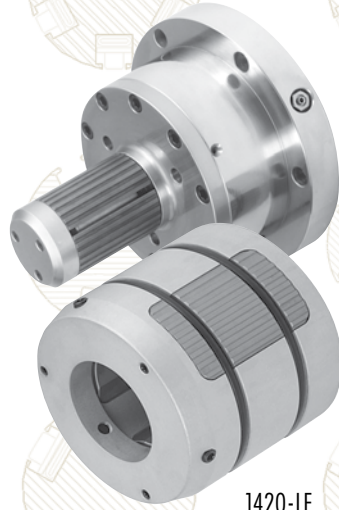

1420-LF
shown with adapter

MULTIPLE BLADDER CHUCK ADAPTER

Quick changeovers plus all the benefits of the 1460 multiple bladder design

- Adapters can be used in pairs or made as a full-width sleeve with no re-positioning of chucks required
- Grips cores with nearly twice the force of conventional pneumatic chuck adapters
- Available with Centering metal ledges
- Quick and easy maintenance
- Assembled with split collar mount
- Available in Lightweight Spyder design for larger diameters up to 16"

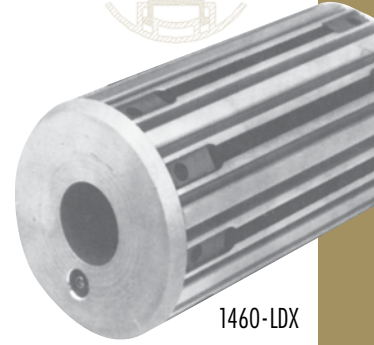

1460-LDX

TORQUE CHUCKS

Low cost, heavy duty, and easy to use.

- Uses web tension to expand; non-slip gripping power exerted in either direction
- Flange mounted or single center bolt mounted
- Simple design eliminates wearing parts
- Available for standard corrugating and sheet operations

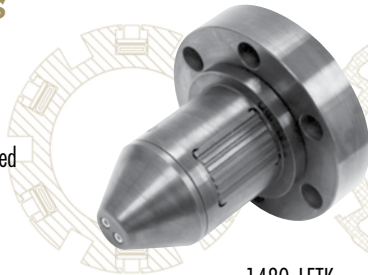

1480-LFTK

GOLDENROD SAFETY CHUCKS

Widest range of standard models and socket sizes available from inventory

- Available in Tilt Plate, foot or flange mounting
- U-square, V-square, and VO square/round sockets
- Manual unlocks and finger guards standard
- Sidelay adjustable models with optional Skew Base
- Air-Thru and air-operated models for rotary union connection

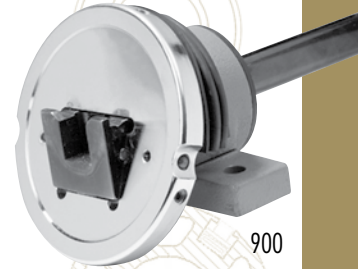

900

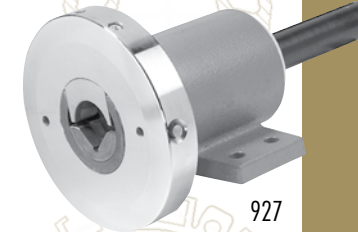

927



935

AXIAL CHUCKS

- Machine arms exert side pressure against the core to expand the lugs
- Flange mounted
- No tools or air pressure required
- Available with various diameter core adapters for easy changeover



1480-LGAX

SINGLE BLADDER PNEUMATIC CHUCK ADAPTER (TIRE CHUCKS)

Lightweight and economical bar-mounted 1440 models

- Large surface area contact with core ID
- Molded rubber bladder always deflates below chuck body
- Air hose connections to inflate chucks in series
- Available from 3" to 16" diameters with custom passing bores



1440-RC

Goldenrod tire chucks are available in a wide variety of sizes



Sheeter unwind



Tissue Mill



Heavy duty



Goldenrod 1250 DFX shaft on duplex winder



Shaft handling



Square round safety chuck



Locked-core shaft in two-drum winder



Heavy duty shaftless core chuck



Founded in 1986, Goldenrod Corporation is a leading North American manufacturer of winding shafts, chucks and related equipment for the converting, paper, film, foil, textile and metals industries. The Goldenrod/Svecom partnership is the largest manufacturer of winding shafts, chucks, and shaft handling equipment in the world. We are a truly global company dedicated to one thing – servicing the needs of our customers.



GOLDENROD



CORPORATION

Goldenrod Corporation – an affiliate of Svecom P.E.



P.O. Box 95 • 25 Lancaster Drive, Beacon Falls, CT 06403 USA / Toll Free 1-800-465-3763 (GOLDROD) • Tel. (203) 723-4400 • FAX (203) 723-8230

www.goldenrodcorp.com